

SEILWINDE

450 - 900 BASIC

BETRIEBSANLEITUNG

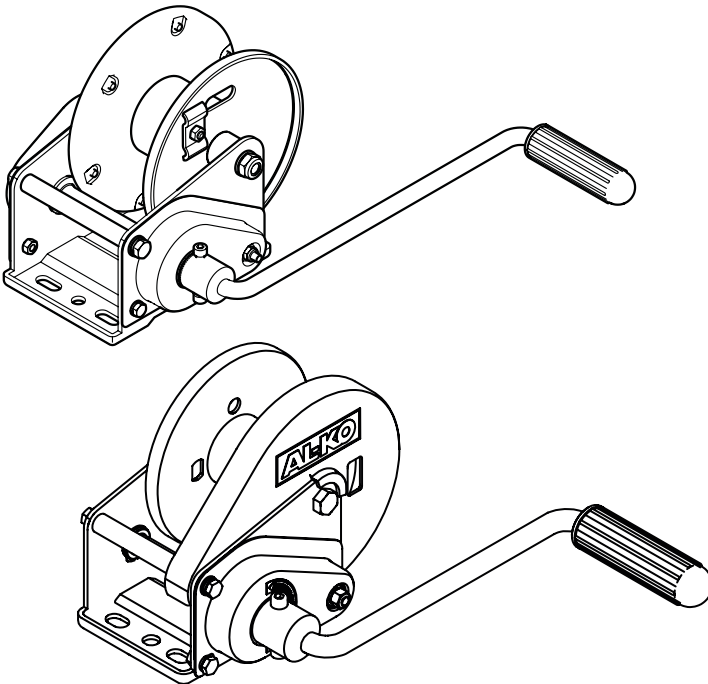

<u>D</u>
<u>EN</u>
<u>NL</u>
<u>FR</u>
<u>ES</u>
<u>IT</u>
<u>SL</u>
<u>PT</u>
<u>PL</u>
<u>CS</u>
<u>SK</u>
<u>HU</u>
<u>DA</u>
<u>SV</u>
<u>NO</u>
<u>FI</u>
<u>RU</u>
<u>EL</u>



Inhaltsverzeichnis

D	Original-Betriebsanleitung.....	4
EN	Original operating manual.....	10
NL	Vertaling van de originele gebruikershandleiding.....	16
FR	Traduction du manuel utilisateur original.....	22
ES	Traducción del manual original de instrucciones.....	28
IT	Libretto di istruzioni originale.....	34
SL	Prevod originalnih navodil.....	40
PT	Tradução do manual de instruções original.....	46
PL	Tłumaczenie oryginalnej instrukcji obsługi.....	52
CS	Překlad originálního návodu k použití.....	58
SK	Preklad originálneho návodu na použitie.....	64
HU	Eredeti használati útmutató.....	70
DA	Oversættelse af den originale brugsanvisning.....	76
SV	Översättning av originalbruksanvisning.....	82
NO	Oversettelse av den originale bruksanvisningen.....	88
FI	Alkuperäisen käyttöohjeen käänös.....	94
RU	Перевод оригинального руководства по эксплуатации.....	100
EL	Μετάφραση εγχειριδίου οδηγιών χρήσης.....	107

© 2017

AL-KO Vehicle Technology, Germany

This documentation - or excerpts thereof - may only be copied or made accessible to third parties with the express permission of the AL-KO VT. We reserve the right to make functional modifications to reflect technological advances.

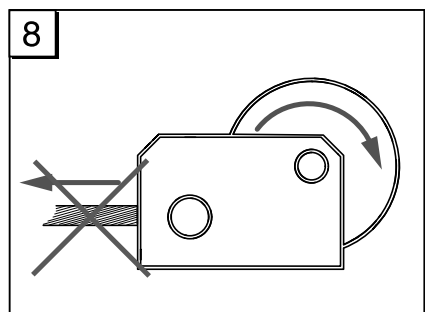
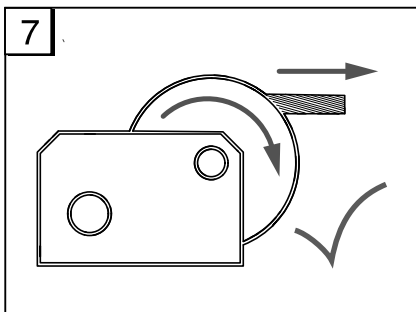
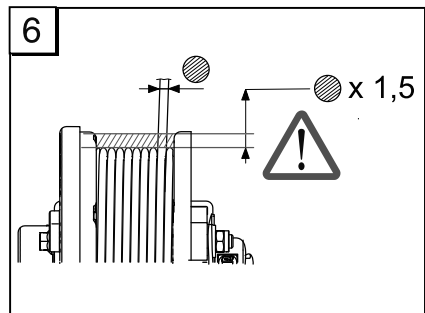
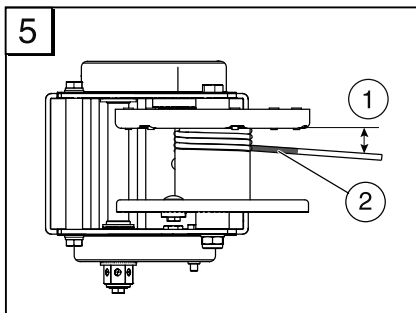
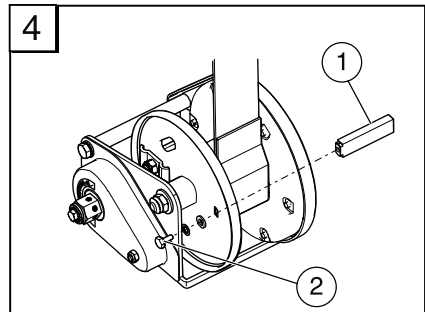
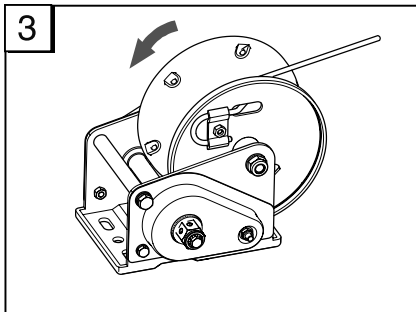
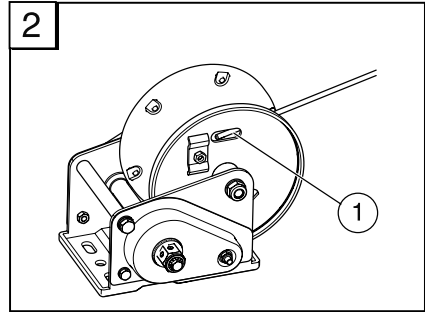
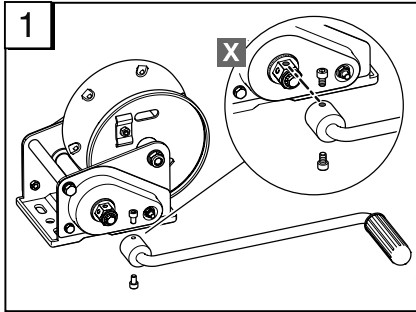

ORIGINAL OPERATING MANUAL

Contents

About this manual.....	10
Product description.....	10
Technical data.....	10
Safety instructions.....	11
Installation.....	11
Operation.....	12
Maintenance and care.....	12
Repair.....	14
Troubleshooting.....	14
EC declaration of conformity.....	15

ABOUT THIS MANUAL

- Please read this document before use. This is essential for safe working and trouble-free handling.
- Comply with the safety and warning instructions in this documentation and on the product.
- This document is a permanent component of the described product, and should remain with the machine if it is sold to someone else.

TECHNICAL DATA

Type	450	900
Max. load daN (kg) (tensile load)		
Lowest cable position	450	900
Highest cable position	170	330
Gear reduction ratio	3.5: 1	8.75: 1
Rope *	Ø5 mm	Ø7 mm
Minimum breaking force (F min)	14 kN	27 kN
Drum capacity (m)	15	17
Strap **	35-45x2.5	50x2.5
Minimum breaking force (F min)	35 kN	63 kN
Drum capacity (m)	3.5 m	5 m
Pull strap (not permitted for lifting)	48x1	52x1.4
Minimum breaking force (F min)	15 kN	25 kN
Drum capacity (m)	6 m	7 m
Minimum load (kg)	25	25
Permitted ambient temperature	- 20° to + 50°C	

* according to EN 12385-4 (cable class 6x19 / 6x19 M / 6x19 W - / WRC)

Explanation of symbols



CAUTION!

Following these warning instructions can help to avoid personal injuries and/or damage to property.



Special notes for ease of understanding and regarding handling.

PRODUCT DESCRIPTION

Cable winches of types:

- 450 BASIC
- 900 BASIC

are only to be used to lift, lower and pull the loads listed in the technical data provided.

Cable winches are not suitable for:

- Stages and studios (BGV C1)
- Moveable personnel lifting equipment (BGR 159)
- Construction hoists
- Motor operation
- Continuous operation

Cable winches are not permitted in:

- Potentially explosive atmosphere
- Corrosive atmosphere

** acc. to DIN EN 13157 (7-times safety for the strap required)

SAFETY INSTRUCTIONS



CAUTION!

Danger of brake release!

The load pressure brake can release due to vibration. The cable winch should not be used to secure loads! Do not remove the crank while under load!

- Danger of fatal injury! - Never stand under suspended loads!
- Risk of accidents! - The brake system can overheat during extended lowering of loads. No continuous operation!
 - ⇒ *Maximum lowering duration 2 - 5 minutes depending on the load.*
- Only use ropes for which the hook is firmly attached to the rope via a pressed rope loop. End connections according to EN 13411-3, with thimbles according to 13411-1.
 - ⇒ *If not otherwise stated in the EN standards listed above, the rope connections must be able to withstand a force of at least 85% of the minimum breaking force of the rope without a break!*
- Hook and connecting device (triangle) must offer 4-times safety with cables and straps. No permanent distortion is allowed under static load with 2-times the nominal load. At 4-times static load, bending open or deformation is permitted, however the load must still be securely held (see EN 13157). Alternatively, a hook acc. to EN 1677-2 with guaranteed safe working load must be used.
- Sharp edges! Damage from scrapes, crushing, cuts. Always wear work gloves.
- Observe the required breaking load when using a strap.
 - ⇒ *The breaking force of the stitched strap must be at least 7 times the specified tensile force in the lowest cable position.*
- Do not knot together ropes / straps.
- Do not expose straps to acids or bases.
- Use a cover to protect straps from moisture and constant solar radiation.
- Do not exceed the tensile forces specified in the technical data.
- Always used non-twisting or low-twisting ropes for lifting a freely suspended load that could rotate during the lifting procedure!

INSTALLATION

Mounting the crank



The safety screws must lie over the recess on the hex connection (1/X)

1. Tighten the safety screws.



CAUTION!

Only use ropes for which the hook is firmly attached to the rope via a pressed rope loop.



When under load, at least two cable windings must remain on the drum. Mark the cable end with a colour.

Mounting the cable

1. Insert the steel cable from the inside to the outside through the oblong hole in the cable drum (2-1).
2. Insert the cable end with a large loop into the clamp and lightly tighten the hex nut (3).
3. Pull the loop back to the clamp and tighten the hex nut with a maximum of 10 Nm.
4. Wind up the cable by two windings.
 - ⇒ *To do so, turn the crank in the "Lift" direction.*
5. Mark the cable end with a colour (5-2).

Mounting the strap (option)

Our winches can optionally be used with a special loop strap instead of a cable.



CAUTION!

Risk of accidents!

The breaking force of the stitched strap must be at least 7 times the specified tensile force in the lowest cable position.



When mounting the strap, please note:
- Always turn the crank in the "LIFT" direction.

Mounting the strap

1. Push the AL-KO insertion element through the strap loop (4-1) and secure with a washer, serrated washer and screw (4-2).
2. Wind up the strap by two windings and mark the strap end with a colour.

Attaching the cable winch

Type	Fastening material	Torque
450 900	<ul style="list-style-type: none"> ■ 3 screws M10 grade 8.8 ■ 3 washers Ø10.5 DIN 125A 	49 Nm

Deflection pulleys

The minimum diameter of the deflection pulleys must be 12 times that of the cable diameter.

- Example:
 - Cable thickness Ø 7 mm
 - Deflection pulley Ø 84 mm

OPERATION



CAUTION!

Danger of brake release!

The load pressure brake can release due to vibration.

The cable winch should not be used to secure loads!

- Danger of fatal injury! Never stand under suspended loads!
- Risk of accidents! The brake system can overheat during extended lowering of loads. Adhere to the cooling periods.
 - ⇒ *Maximum lowering duration 2 - 5 minutes depending on the load.*
- Check braking function of the cable winch. There must be a clicking sound when turning in the "lifting" direction!
- Check the rope / strap for damage and replace if necessary.
- The rope / strap should not be run over sharp edges.
- When winding up the rope / strap without a load, keep it under a slight tension. For proper braking function, a **minimum load of 25 kg** is required.
- Only wind up a cable/strap under load to the point that there is an overhang on the flanged wheels of at least 1.5x the cable diameter (6).

Cable winch operation

Raising, pulling the load

1. Turn the crank clockwise.

Holding the load

1. Release the crank.
 - ⇒ *The load is kept in the same position.*

Lowering the load

1. Turn the crank anti-clockwise.
 - ⇒ *The integrated brake prevents the crank from kicking back.*

Deflection angle



When winding or unwinding, the deflection angle must not exceed 4° (5-1).

MAINTENANCE AND CARE



CAUTION!

Sharp edges!

Damage from scrapes, crushing, cuts. Always wear work gloves.



CAUTION!

Risk of injury

At the end of maintenance and repair work, reattach all covers with the original screws!



CAUTION!

Danger from wear!

The winch operator must check the cables/straps for wear before every use (DIN ISO 4309/BGR 500). Replace damaged cables/straps immediately.

- The cable winch may only be inspected and maintained by trained technicians.
- The brake mechanism was treated by the manufacturer with a special grease (Wolfracoat 99113). Other oils or greases are not permissible.

Inspecting the cable winch

The cable winch must always be inspected by a trained technician:

- Before initial start-up
- Every time the unit is remounted

- Once a year
 - ⇒ *Trained technicians are persons with the necessary technical knowledge to inspect the work equipment on account of their professional training, experience and recent occupational activities.*
 - Please also note any other applicable national regulations.*

Maintenance intervals

- When used regularly to 100% of the rated load: after raising and lowering by 100 m
- When used regularly to 50% of the rated load: after raising and lowering by 200 m

Perform the following tasks at these intervals:

- Inspection work
- Lubrication

Inspection work

- Check that the crank moves freely
- Check that the locking catch engages
- After raising and lowering the winch by 100 m, check the wear of the brake discs and the bonded brake pad.
 - ⇒ *The brake pad must be at least 1.5 mm thick.*

Oil and lubricating points

The winch is greased before delivery. Regrease the following points regularly:

- Drum hub
- Ring gear
- Bearing bushes of the drive shaft
- Crank thread

Grease recommended by AL-KO:

- OMV Whiteplex multipurpose grease.
- Staburags NBU12K multipurpose grease.



CAUTION!

Danger from wear!

The winch operator must check the cables/straps for wear before every use (DIN ISO 4309/BGR 500). Replace damaged cables/straps immediately.

- The cable winch may only be inspected and maintained by trained technicians.
- The brake mechanism was treated by the manufacturer with a special grease (Wolfracoat 99113). Other oils or greases are not permissible.



CAUTION!

Danger of brake release!

The load pressure brake can release due to vibration. The cable winch should not be used to secure loads! Do not remove the crank while under load!

- Danger of fatal injury! - Never stand under suspended loads!
- Risk of accidents! - The brake system can overheat during extended lowering of loads. No continuous operation!
 - ⇒ *Maximum lowering duration 2 - 5 minutes depending on the load.*
- Only use ropes for which the hook is firmly attached to the rope via a pressed rope loop. End connections according to EN 13411-3 with thimbles according to 13411-1.
 - ⇒ *If not otherwise stated in the EN standards listed above, the cable end connections must be able to withstand a force of at least 85% of the minimum breaking force of the cable without a break.*
- Hook and connecting device (triangle) must offer 4-times safety with cables and straps. No permanent distortion is allowed under static load with 2-times the nominal load. At 4-times static load, bending open or deformation is permitted, however the load must still be securely held (see EN 13157). Alternatively, a hook acc. to EN 1677-2 with guaranteed safe working load must be used.
- Sharp edges! Damage from scrapes, crushing, cuts. Always wear work gloves.
- Observe the required minimum breaking load when using a strap.
 - ⇒ *The breaking force of the stitched strap must be at least 7 times the specified tensile force in the lowest cable position.*
- Do not knot together ropes / straps.
- Do not expose straps to acids or bases.
- Use a cover to protect straps from moisture and constant solar radiation.
- Do not exceed the tensile forces specified in the technical data.
- Always used non-twisting or low-twisting ropes for lifting a freely suspended load that could rotate during the lifting procedure!

REPAIR

Repair work



CAUTION!

Repair work may be carried out only by AL-KO service centres or authorised specialist workshops.

- For repairs, a region-wide network of AL-KO service stations is available to our customers in Europe.
- You can obtain a list of service points directly from us at: www.al-ko.com

Replacement parts are safety parts!

- For the installation of replacement parts into our products, we recommend the use of original AL-KO parts, or parts that we have expressly approved for installation.
- For the clear identification of replacement parts, our service centres require the replacement part identification number (ETI).

TROUBLESHOOTING

Malfunction	Cause	Solution
Load will not hold	Rope / Strap wound up incorrectly ⇒ <i>Turning direction incorrect when lifting</i>	Fit rope / strap correctly
	Brake worn or faulty	Check brake parts and replace worn parts
	Brake disc moist or oily	Clean or replace brake discs
Load pressure brake does not open or close	Brake disc mechanism or brake discs braced	Cable winch must not be under load! Loosen the brake by gently hitting the crank in the "lowering" direction with the palm of your hand ⇒ <i>You may need to block some gear wheels until the crank loosens.</i> ⇒ <i>Grease the crank attachment thread</i>
Difficult lowering without or without load	Crank attachment thread is fixed	Grease the crank attachment thread



If you encounter any malfunctions that are not listed in this table or which you cannot rectify yourself, please contact our responsible customer service.

EC DECLARATION OF CONFORMITY

We herewith declare that this product, in the version introduced into trade by us, complies with the relevant provisions of the EC directive and the harmonised standards named in the following.

Product

AL-KO cable winch

Manufacturer

ALOIS KOBER GmbH
Ichenhauser Str. 14
89359 Kötz Germany

Duly authorised person

ALOIS KOBER GmbH
Head of Tech. Development
Standardisation / Data Management
Ichenhauser Str. 14
89359 Kötz Germany

Type

450 BASIC
900 BASIC

EC directives

2006/42/EC

Harmonised standards

DIN EN 13157
EN ISO 12100

Series

11817M06 - 11820M06

Kötz, 30/05/2017

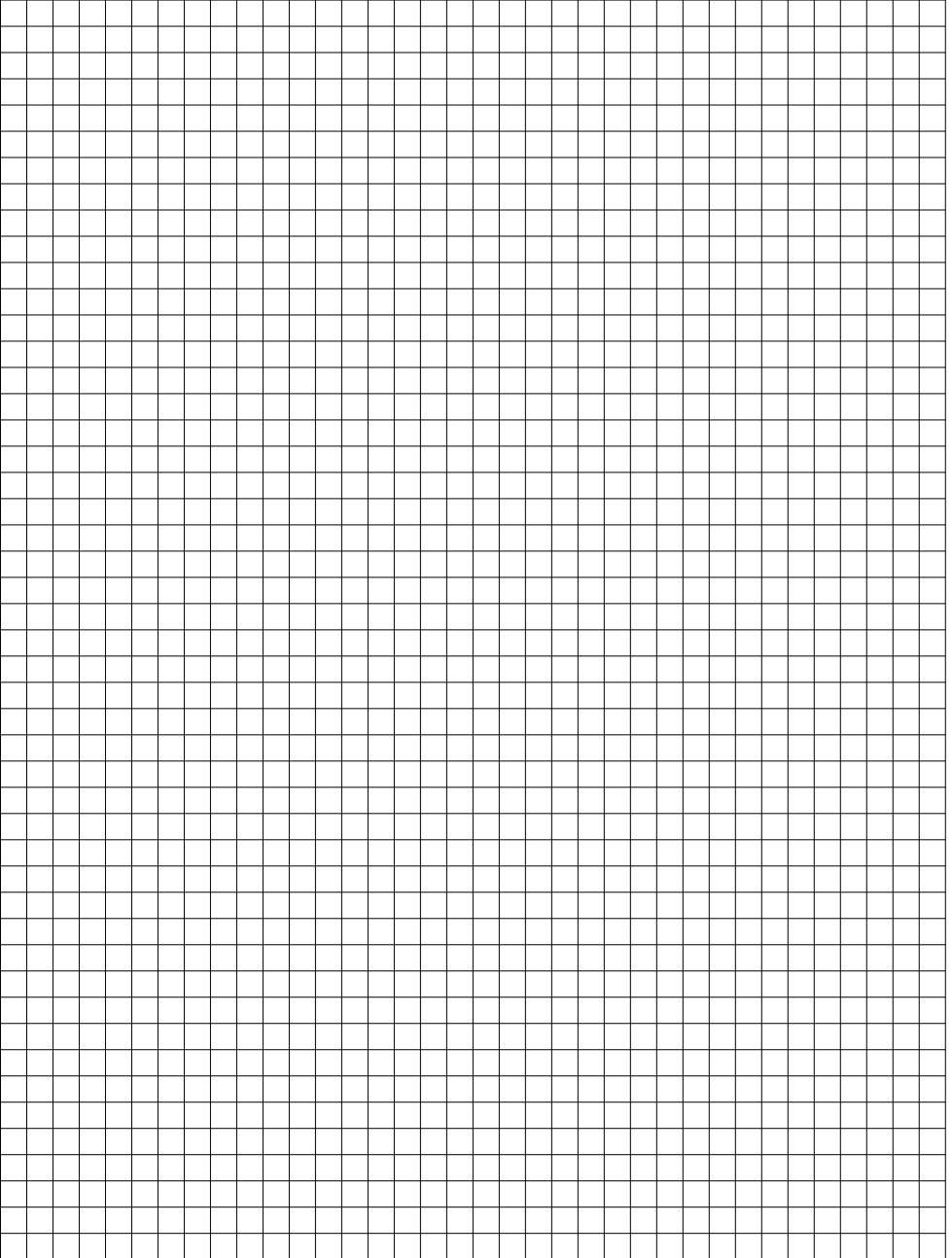

Dr Frank Sager
Technical Leader

NOTICE

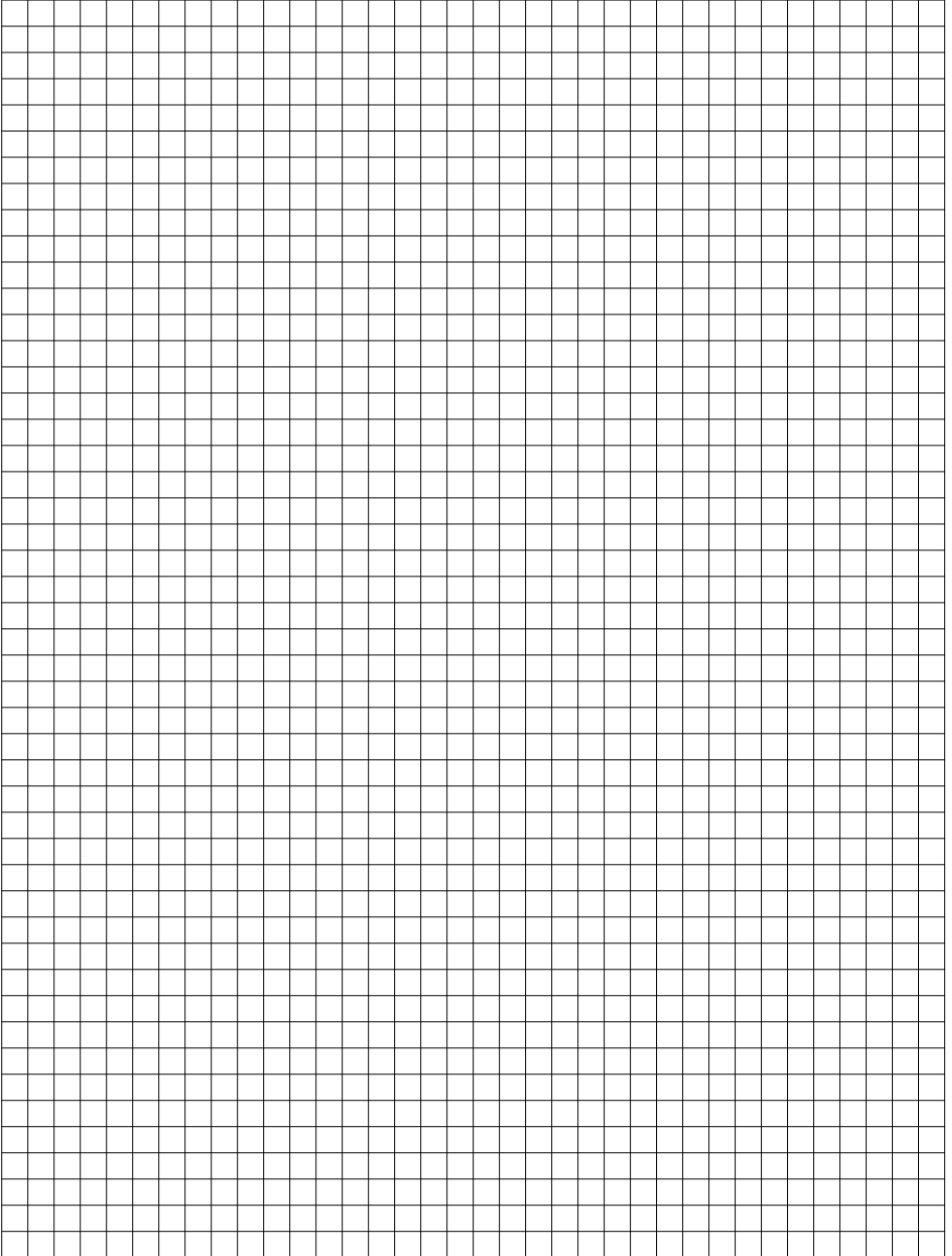
NOTICE

Land	Firma	Telefon	Email
AT	AL-KO Technology Austria GmbH	(+43) 5282 / 3360-700	vertrieb.fzt@al-ko.at
AU	AL-KO International Pty. Ltd.	(+61) / 3-9767-3700	info@al-ko.au
BG	AL-KO TRAILCO (Pty.) Ltd.	(+27) 16421 - 4791	infocpt@al-ko.co.za
BR	AL-KO Brasil Participacoes Ltda.	(+55) (11)2305 / 1053	brasil@al-ko.com
CN	AL-KO (Yantai) Machinery Co. Ltd.	(+86) 535672 - 7751	info@al-ko.cn
DE	ALOIS KOBER GMBH	(+49) 8221/97-0	fahrzeugtechnik@al-ko.de
ES	AL-KO Espana S.A.U.	(+34) 976/46-2280	info.zaragoza@al-ko.es
EN	AL-KO KOBER Ltd.	(+44) 1926/818-500	mail@al-ko.co.uk
FR	AL-KO S.A.S.	(+33) 3/8576-3500	al-ko@al-ko.fr
IT	AL-KO KOBER GmbH	(+39) 045/8546-011	info@al-ko.it
NL	AL-KO KOBER B.V.	(+31) 74/255-9955	info@al-ko.nl
PL	AL-KO Technology Sp. z.o.o.	(+48) 61/816-1925	al-ko@al-ko.pl
RU	OOO AL-KO KOBER technology RUS	(+7) 499/16887-16	info@al-ko.msk.ru
SV	AL-KO KOBER AB	(+46) 31/57-8280	question@al-ko.se
CS	AL-KO KOBER Spol. S.R.O.	(+420) 577/454-342	info@al-ko.cz
TR	AL-KO Teknoloji ve Araç Ltd. ŞTi.	(+90) 216/340 51 28	info@al-ko.com.tr