

# BETRIEBSANLEITUNG

## AL-KO Achse ungebremst

KEGELROLLENLAGER

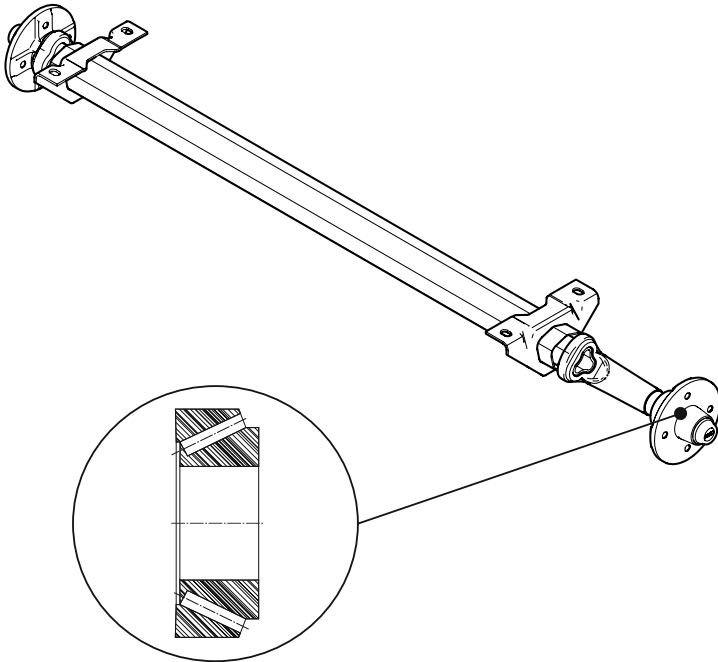

- DE
- EN
- NL
- FR
- ES
- PT
- IT
- SL
- PL
- CS
- SK
- HU
- DA
- SV
- NO
- FI
- ET
- LT
- LV
- RU
- EL
- TR



## SAFETY INSTRUCTIONS

- Risk of accident due to rolling trailer. Secure the trailer with wheel chocks prior to uncoupling!
- Risk of accident due to rolling trailer. Always secure the trailer with chocks prior to performing any maintenance and care jobs!
- An AL-KO axle is not allowed to be welded!
- Undetected bearing damage can progress to the point that the bearing is completely destroyed and this will lead to the wheel running off the axle. If you suspect bearing damage, see your specialist service centre! Trailers should only be operated in perfect condition!
- In the event of faults while driving, contact a trained specialist or our AL-KO Service.
- Type information is not allowed to be rendered illegible due to painting or being covered by components

## MAINTENANCE AND CARE



### CAUTION!

Have all maintenance and repair work exclusively carried out by trained specialists or our AL-KO Service. In the event of all faults and driving noises, contact a workshop licensed by AL-KO.



In order to prevent white rust formation (defective appearance):

- Ensure sufficient air circulation during storage.
- After driving in winter, rinse hot-dip galvanised surfaces with clean water.
- Re-lubricate or oil articulation and bearing points!



In the case of boat trailers which are driven into water, the wheel hub bearings should be re-lubricated shortly after being immersed in the water.

### Maintenance intervals



Maintenance intervals must be complied with!

The maintenance intervals will be shorter if there is heavy use.

Initial inspection after 1500 km or 6 months

- Check the axial play of the wheel hub bearing, re-adjust if necessary.

Every 5000 km or 12 months

- Check the level and condition of the grease on the bearings, re-lubricate if necessary.
- Check the axial play of the wheel hub bearing, re-adjust if necessary.

### Replacement parts



Replacement parts are safety parts!

- For the installation of replacement parts into our products, we recommend the use of original AL-KO parts, or parts that we have expressly approved for installation.
- For the clear identification of replacement parts, our service stations require the replacement part identification number (ETI).

Member of **DEXKO**  
G L O B A L

**ALOIS KOBER GMBH**

Ichenhauser Str. 14

89359 Kötz

Germany

Fon +49 8221 97-0

info@alko-tech.com

**www.alko-tech.com**