

# BETRIEBSANLEITUNG

## Auflaufeinrichtung

V / VIERKANT

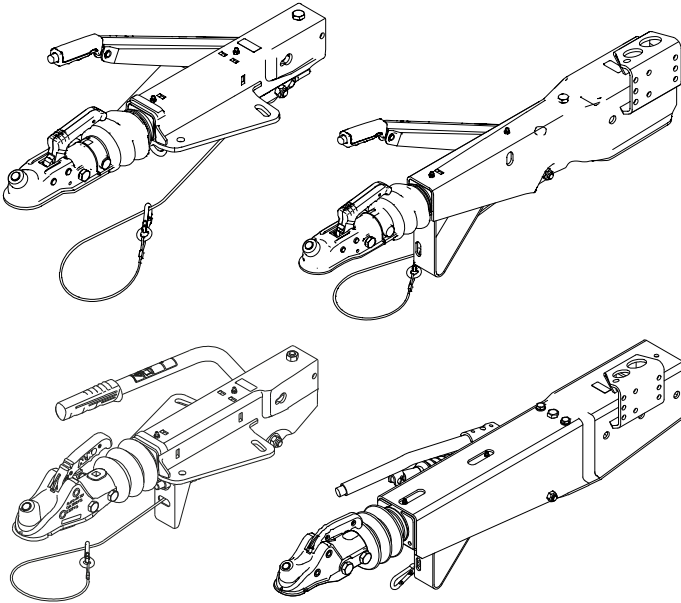

DE
EN
NL
FR
ES
PT
IT
SL
HR
PL
CS
SK
HU
DA
SV
NO
FI
ET
LT
LV
RU
UK
BG
RO
EL
TR



---

## Sprachenverzeichnis

DE	Original-Betriebsanleitung.....	5
EN	Translation of original operating manual.....	10
NL	Vertaling van de originele handleiding.....	15
FR	Traduction du manuel d'utilisation original.....	20
ES	Traducción del manual de instrucciones original.....	26
PT	Manual de instruções original.....	32
IT	Traduzione delle istruzioni per l'uso originali.....	38
SL	Originalna navodila za uporabo.....	44
HR	Originalne upute za uporabu.....	49
PL	Oryginalna instrukcja obsługi.....	54
CS	Překlad originálního návodu k použití.....	60
SK	Preklad originálneho návodu na použitie.....	65
HU	Az eredeti használati útmutató fordítása.....	70
DA	Original betjeningsvejledning.....	75
SV	Översättning av originalbruksanvisningen.....	80
NO	Original bruksanvisning.....	85
FI	Alkuperäisen käyttöohjeen käänös.....	90
ET	Algupärane kasutusjuhend.....	95
LT	Originalios naudojimo instrukcijos vertimas.....	100
LV	Orģinālās ekspluatācijas instrukcijas tulkojums.....	105
RU	Перевод оригинального руководства по эксплуатации.....	110
UK	Переклад ориģинальної інструкції з експлуатації.....	116
BG	Ориģинално ръководство за експлоатация.....	122
RO	Instrucțiunile originale de utilizare.....	128
EL	Μετáφραση των πρωτότυπων οδηγιών χρήσης.....	134
TR	Orijinal İşletim Kılavuzu.....	140

© 2024

ALOIS KOBBER GMBH, Germany

This documentation - or excerpts thereof - may only be copied or made accessible to third parties with the express permission of the ALOIS KOBBER GMBH. We reserve the right to make functional modifications to reflect technological advances.

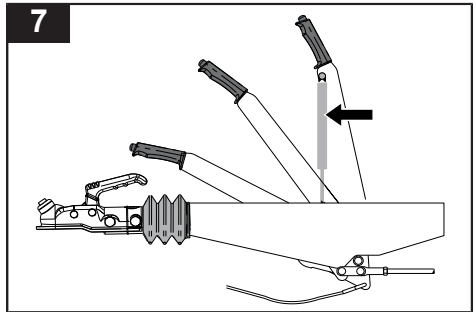
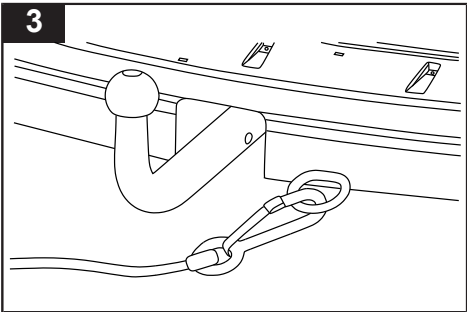
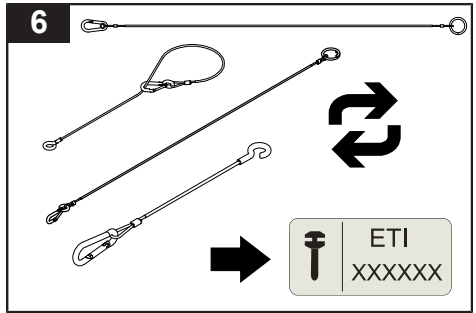
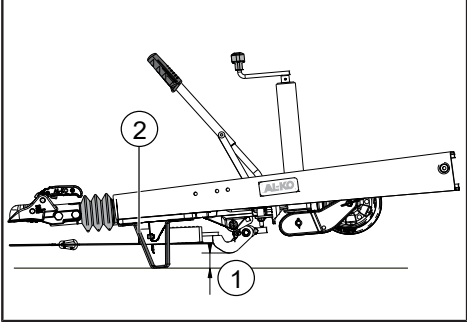
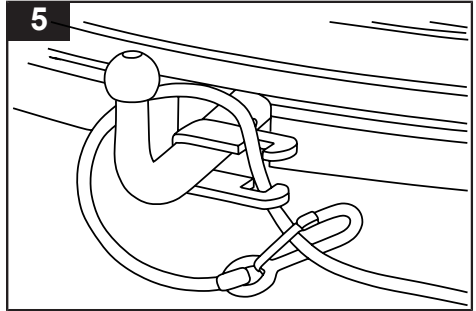
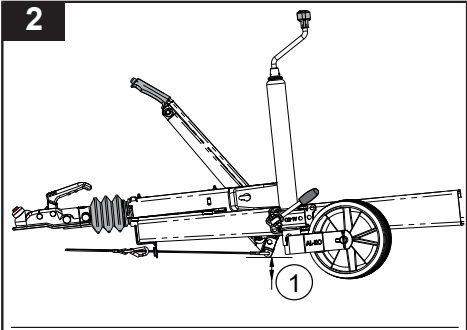
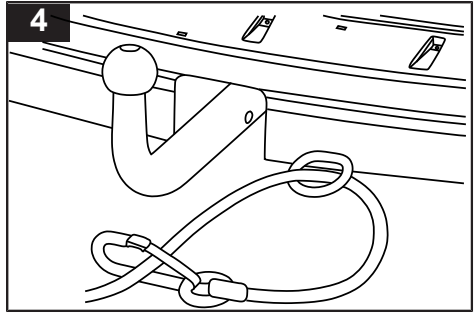
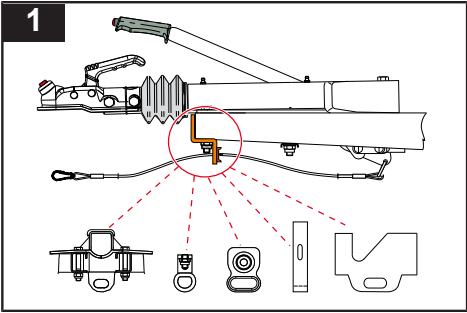

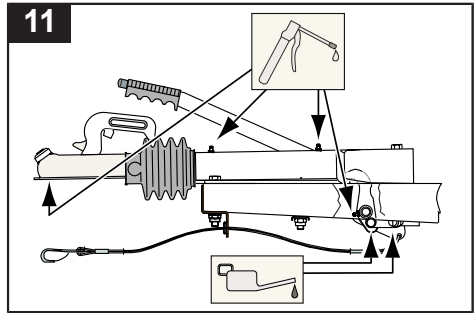
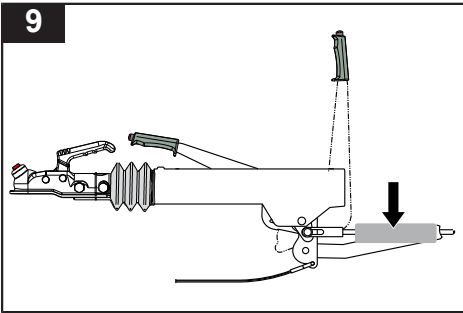
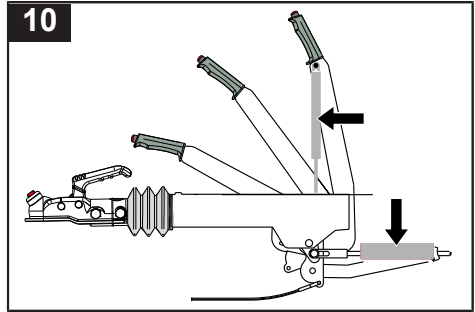
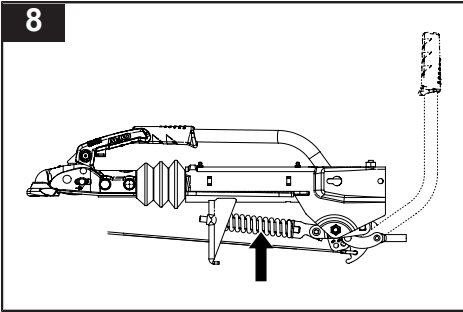

**12**

AL-KO/ MADE IN ITALY  
 AL-KO 251 S Ausf. A □  
 GA 1500-2700 kg S 120 kg  
 ECE Pr.-Nr. 361-0044-97

ZE 251 S  
 E Dc 24,5  
 S 120

Ⓔ 55R-01 0227

AL-KO D50  
 S Dc 31,0  
 S 350

Ⓔ 55R-01 0242

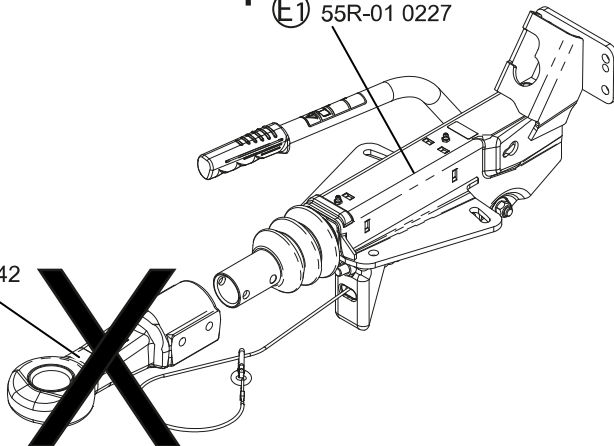

## TRANSLATION OF ORIGINAL OPERATING MANUAL

### Table of contents

About this documentation.....	10
Product description.....	10
Safety instructions.....	11
Installation.....	11
Operation.....	11
Maintenance and servicing.....	13
Disposal.....	13
Troubleshooting.....	14

### ABOUT THIS DOCUMENTATION

- Read this documentation prior to commissioning/operation. This is a prerequisite for safe work and problem-free handling.
- Please observe the safety and warning notices in this documentation and on the product.
- This documentation is a permanent part of the product described and should be handed over to the buyer if sold.
- Illustrations in this document are for reference purposes and may actually deviate from the product in terms of the details.

### Danger levels of warning notices

The following danger levels alert you to potential dangerous situations:

#### DANGER!



Indicates a dangerous situation which, if not avoided, will result in death or serious injury.

#### WARNING!



Indicates a dangerous situation which, if not avoided, may result in death or serious injury.

#### CAUTION!



Indicates a dangerous situation, which if not avoided, may result in minor or moderate injuries.

#### NOTICE!

Material damage: The product or an object in its environment may be damaged.

### Symbols



Special notes to improve comprehension and handling.

Single step:



Numbered instruction:

- 1.
- 2.
- 3.

Outcome of the instruction:



### PRODUCT DESCRIPTION

#### Designated use

The overrun hitch is a component of the trailer's brake system, and may be used only, after being completely installed and tested, for connecting the trailer to the towing vehicle.

Any other or additional use shall be deemed improper use. The manufacturer shall not accept liability for any damage incurred as a result.

#### Weight range

Permitted weight range according to type information:

- V / Square 450 - 3500 kg

#### Possible misuse

##### WARNING!



#### Risk of accident due to failure of the handbrake

Under tensile load the eye bends and the handbrake's spring pack jumps out of the holder.

- ▶ Do not use the eye of the breakaway cable guide for towing and pulling.

- The gross weight rating is stamped onto every overrun hitch. The gross weight of the trailer must not exceed this value.

## SAFETY INSTRUCTIONS

### Breakaway cable

- The breakaway cable must always be guided through the eye of the breakaway cable guide (if available). (1)
- Attach the breakaway cable in such a way that cornering does not cause problems.
- The breakaway cable must not wrap around the jockey wheel.
- When attaching the breakaway cable, observe the country-specific regulations.
- If there is an eye on the vehicle, hook in the breakaway cable directly.
- The breakaway cable defined by the number in the spare part identification number (ETI) card is to be used in the case of replacement (6). When using the correct breakaway cable, a reliable breakaway function is guaranteed.

### Jockey wheel

- Make sure the jockey wheel is seated firmly.

### Parking

- If the trailer is uncoupled from the towing vehicle, then the following must be done:
  - the parking brake must be engaged.
  - the trailer must be secured with two additional chocks.
- When parking or laying up the vehicle/trailer combination, engage the trailer's parking brake.

## INSTALLATION

### WARNING!



#### Risk of accidents

If the handbrake makes contact with the road surface, the emergency brake function is no longer ensured.

- ▶ In case of emergency, ensure that the handbrake lever remains accessible after the breakaway cable has been used to engage it (handbrake applied).



AL-KO recommends mounting a skid bracket (2-2) and carrying out a clearance check with fully engaged emergency brake lever (emergency brake is activated).

### CAUTION!



#### Risk of injury from the handbrake lever springing upwards

The handbrake lever on variants with handbrake without gas spring support can spring upwards.

- ▶ Remove cable ties on the trailer and brake rod connection only after installation.

- The attachment to the vehicle must meet the requirements of Directive ECE R55-01, Annex 7.
- Any applicable installation guidelines must be taken into consideration.
- The hand-brake lever may not rest on the ground in an emergency. It is essential that appropriate clearance be provided (2-1)!
- So that the screw heads fit better to the elongated holes of the overrun device, we recommend reinforced washers (Ø13 DIN 7349 or a similar washer that is at least 4 mm thick).

## OPERATION

### NOTICE!

The overrun device AE 251S TOTP must not be combined with the push-on eyelet D50 (12).

### NOTICE!

#### Material damage due to improper handling

- ▶ Do not use the handbrake lever as a manoeuvring handle.

## Coupling (coupling head)

### WARNING!



#### Danger of emergency brake failure

- ▶ The breakaway cable must always be guided through the eye of the breakaway cable guide (if available).

1. Position the ball coupling over the towing hitch.
2. Open the ball coupling.

3. Turn the jockey wheel crank clockwise until the ball coupling engages.
4. Keep turning the jockey wheel crank until the wheel is fully retracted. The support shoe must be securely engaged in the recess of the outer tube.
5. Open the clamp.
6. Pull the jockey wheel upwards as far as possible.
7. Tighten the clamp.
8. Connect the power cable with the towing vehicle.
9. Route the breakaway cable through the eye of the breakaway cable guide.
10. Attach the breakaway cable to the towing vehicle using a spring hook (3, 4, 5).
11. Release the handbrake lever and remove the wheel chocks.

## Coupling (drawbar eye)

1. Hitch up the drawbar eye in the hitch mouth.
2. Turn the jockey wheel crank clockwise until the wheel has turned in all the way. The support shoe must be firmly secured in the recess in the outside tube.
3. Open the clamping clip.
4. Pull the jockey wheel as far up as possible.
5. Tighten the clamping clip.
6. Connect the power cable to the towing vehicle.
7. Connect the breakaway cable as described.
8. Remove wheel chocks and release parking brake.

## Handbrake

### ⚠ CAUTION!



#### Risk of injury due to improper handling

- ▶ Always hold the handbrake lever securely in your hand when operating it.
- ▶ Do not allow the handbrake lever to spring upwards automatically in an uncontrolled manner.
- ▶ Ensure you are safely positioned next to the handbrake lever.

### ⚠ CAUTION!



#### Danger of uncontrolled movement

- ▶ Always tighten the handbrake lever fully.
- ▶ The trailer can roll back by 25–30 cm before the full braking force takes effect! Ensure adequate distance when stopping the trailer.

### ⚠ CAUTION!



#### Danger due to uncontrolled release of the handbrake lever

An uncontrolled release of the handbrake lever while the brake system is not connected (brake rod, Bowden cables, brake) may lead to injuries and damage the handbrake lever system.

- ▶ Apply the lever only after the brake rod has been connected.

Ensure correct function when applying the handbrake.

Incorrect function may be noticeable from the following:

- noticeable loss of power
- jerking movement of the handbrake lever
- stiff handbrake
- loose components

For handbrake levers with gas spring support, also from:

- visible corrosion or damage to the gas spring piston rod
- visible oil loss from the gas spring

## Variants

- Handbrake lever with gas spring support (7)
- Handbrake lever with spring set (8)
- Handbrake lever with spring accumulator (9)
- Handbrake lever with gas spring support and spring accumulator (10)

## Applying the handbrake

1. Pull the handbrake firmly past the dead centre point.

## Releasing the handbrake

1. Press and hold lock button\*.
2. Put the handbrake lever back to the starting position above the dead point area.

\*Lock button is not available in all versions

## MAINTENANCE AND SERVICING

### ⚠ WARNING!



#### Danger of the trailer rolling away

- ▶ Before all maintenance and servicing work, always secure the trailer with wheel chocks.



#### Replacement parts are safety parts!

For the installation of replacement parts into our products, we recommend the use of original AL-KO parts, or of parts that we have expressly approved for installation. For the clear identification of replacement parts, our service stations require the replacement part identification number (ETI).



The overrun device forms part of the brake system. Irrespective of the service intervals for the overrun device, the brake system must be inspected for the first time by a specialist workshop after 1500 km or 6 months.

- During maintenance, servicing and inspection work, check all system components for operating safety and correct condition.
- Have damaged components replaced.

## Limited liability

- Checking the brake system does not mean that the prescribed maintenance measures for the overrun hitch can be neglected.
- The manufacturer cannot be held liable for injury to personnel and damage to material attributable to failure to comply with the safety regulations and to carry out the indicated maintenance work.

## Oil and lubricating points

- Lubricate or oil sliding and articulation points every 10,000–12000 km or every 12 months (11).

Lubricant type: Multi-purpose grease to DIN 51825

## Maintenance and care jobs

The formation of white rust on hot dip galvanised vehicle components does not reduce safety, and can be reduced by the following measures:

- When laying up or storing hot dip galvanised components, ensure good air circulation.
- After winter journeys, wash the hot dip galvanised components with clean water (e.g. steam jets).

## Repair work

### ⚠ WARNING!



#### Safety-relevant component

- ▶ Repair work may only be carried out by appropriate specialist companies or our AL-KO service centres.

For repairs, a region-wide network of AL-KO service stations is available to our customers in Europe.

<https://www.alko-tech.com/uk/service-centres>

## Type plate

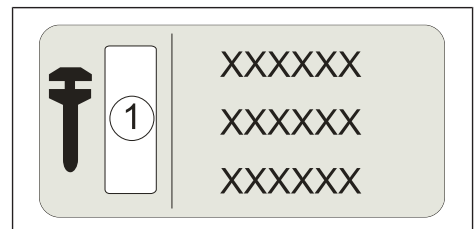

1 Spare part ID number (ETI)

## DISPOSAL



#### Do not dispose of used appliances in household waste!

The packaging, machine and accessories are made from recyclable materials, and must be disposed of accordingly.

## TROUBLESHOOTING

Malfunction	Possible cause	Solution
Inadequate braking effect	Excessive friction losses in the overrun device	Remove dirt and corrosion from the transmission system and brake cable and then check that the system operates smoothly.
	Corrosion on the pull rod	
	Serious damage when manoeuvring	Seek assistance from an AL-KO service centre.
Overheating of the brakes when driving forward	Handbrake not released	Release the handbrake.
	Jockey wheel blocks linkage	Release the jockey wheel and move it to the correct position.
Driving is not smooth, or braking is jerky	Shock absorber defective	Have shock absorber replaced.
Trailer brakes when accelerator pedal is released	Shock absorber defective	Have shock absorber replaced.
Trailer brakes when driving in reverse	Corrosion and/or lack of lubrication for the wheel brake	<ul style="list-style-type: none"> <li>■ Clean and regrease the moving parts of the wheel brake.</li> <li>■ Have worn brake shoes (&lt; 2 mm) replaced.</li> </ul>
Overrun device hits end stop audibly and noticeably	Shock absorber defective	Have shock absorber replaced.
Overrun device overruns or Parking brake too weak to stop trailer moving backwards	Too much air in the transmission device	Have brake system adjusted.
	Brake linings worn	Have brake pads replaced.



If you encounter any malfunctions that are not listed in this table or that you cannot rectify yourself, please contact the responsible service centre.

Member of **DEXKO**  
G L O B A L

**ALOIS KOBER GMBH**

Ichenhauser Str. 14

89359 Kötz

Germany

Fon +49 8221 97-0

[info@alko-tech.com](mailto:info@alko-tech.com)

[www.alko-tech.com](http://www.alko-tech.com)