

BETRIEBSANLEITUNG

AL-KO Achse gebremst - Compactlager

1637 / 2051 / 2361

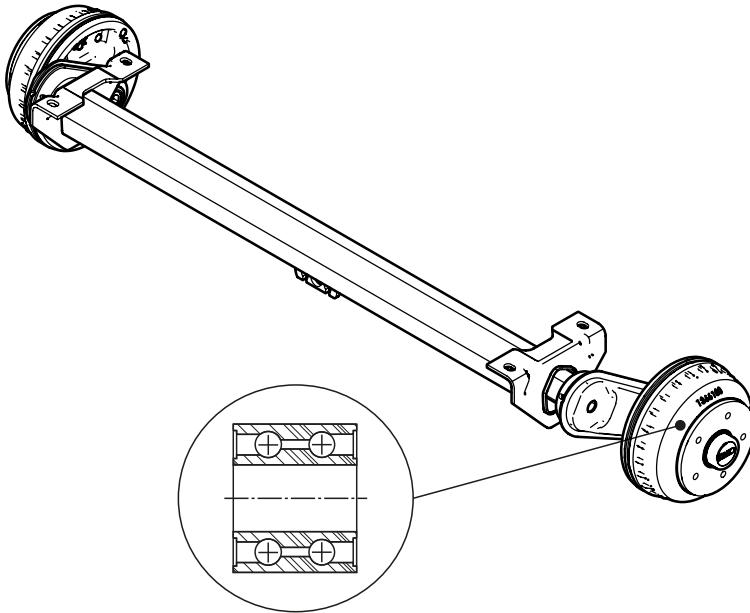

- DE
- EN
- NL
- FR
- ES
- PT
- IT
- SL
- PL
- CS
- SK
- HU
- DA
- SV
- NO
- FI
- ET
- LT
- LV
- RU
- EL
- TR



SAFETY INSTRUCTIONS

- Risk of accident due to rolling trailer. Secure the trailer with wheel chocks prior to uncoupling!
- Risk of accident due to rolling trailer. Always secure the trailer with chocks prior to performing any maintenance and care jobs!
- An AL-KO axle is not allowed to be welded!
- Undetected bearing damage can progress to the point that the bearing is completely destroyed and this will lead to the wheel running off the axle. If you suspect bearing damage, see your specialist service centre! Trailers should only be operated in perfect condition!
- Not all compact bearings are watertight.



Watertight compact bearings can be identified on the dust cap (symbol) or the ETI number on the type plate.

- In the event of faults while driving, contact a trained specialist or our AL-KO Service.
- Trailer rolls backwards until the handbrake force (approx. 25 cm) is fully applied. Always secure trailer with wheel chocks!
- Type information is not allowed to be rendered illegible due to painting or being covered by components

MAINTENANCE AND CARE



CAUTION!

Have all maintenance and repair work exclusively carried out by trained specialists or our AL-KO Service. In the event of all faults and driving noises, contact a workshop licensed by AL-KO.

The maintenance-free compact bearings are greased and sealed for life.



In order to prevent white rust formation (defective appearance):

- Ensure sufficient air circulation during storage.
- After driving in winter, rinse hot-dip galvanised surfaces with clean water.
- Re-lubricate or oil articulation and bearing points!

Maintenance intervals



Maintenance intervals must be complied with!

The maintenance intervals will be shorter if there is heavy use.

Initial inspection after 500 km or 6 months

- Check brake system, adjust if necessary.

Every 5000 km or 12 months

- Check brake system, if necessary
 - Replace brake pads.
 - Adjust brake system.

Every 10,000 km or 24 months

- Maintain the brake system



The trailer brake is subject to increased wear if continuously driven uphill. In the case of commercial trailers, earlier adjustment may be necessary.

Replacement parts



Replacement parts are safety parts!

- For the installation of replacement parts into our products, we recommend the use of original AL-KO parts, or parts that we have expressly approved for installation.
- For the clear identification of replacement parts, our service stations require the replacement part identification number (ETI).

Member of  **DEXKO**
GLOBAL

ALOIS KOBER GMBH

Ichenhauser Str. 14

89359 Kötz

Germany

Fon +49 8221 97-0

info@alko-tech.com

www.alko-tech.com